

Control & Monitoring Relays

Thermostat Relay MXT-10



DESCRIPTION

A thermostat relay for the monitoring or control of temperature in the range -50 to 300°C. The probe is a standard Pt100, either 2 or 3 wire. LED indication of a non-functional probe and relay activated.

When the temperature rises and reaches the determined setpoint, plus the hysteresis, which is adjusted on the front, the relay de-energises. As the temperature falls and passes the setpoint, minus the hysteresis, the relay re-energises. By strapping 2 terminals, the relay can be inverted allowing the thermostat relay to be used for the control of heating as well as cooling systems.

The relay has two analogue 0-10VDC outputs, one for measured temperature and the other for the setpoint.

Features

- 2/3 wire Pt100 input (DIN43760).
- Monitoring or control of temperature - 50 to 300°C in 5 ranges in one version.
- Adjustable Setpoint.
- Hysteresis adjustable $\pm 0,5-20\%$.
- Inversion of the relay contact function - heating/cooling control.
- LED indication of probe failure.
- Outputs.
- SPDT.
- Analogue 0 - 10VDC with ref. to measured temperature.
- Analogue 0 - 10VDC with ref. to setpoint.
- Supply voltage 24VDC, 24/115VAC or 24/230VAC.

VERSIONS/ORDERING CODES

Type:
Thermostat relay

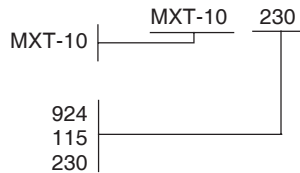

Supply voltage

24V DC
115V AC / 24V AC
230V AC / 24V AC

OPERATION

Temperature monitoring

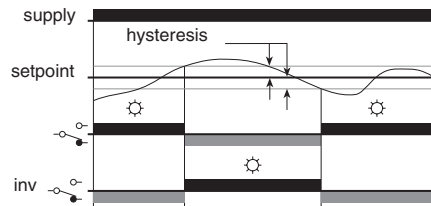

MECHANICAL DIMENSIONS

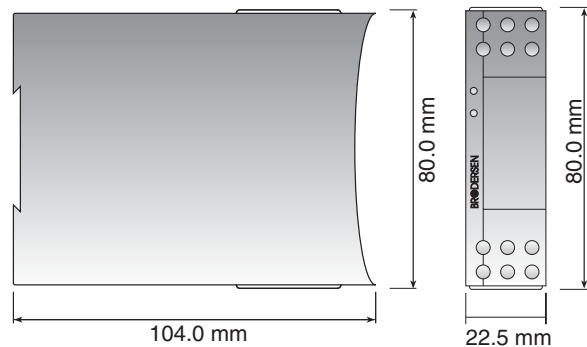

TECHNICAL DATA

Input: Pt-100 probe(DIN 43760), 3 conductors with compensation for cable resistance.

Temperature range: -50-50°C
0-50°C
0-100°C
100-200°C
200-300°C

Temperature drift: Max. 0,05%/°C

Setting accuracy: Typically ± 10%

Hysteresis: ±0,5-20% of chosen area, adjustable

Response time: time constant $\tau = 0,2s$,
Worst case of response time max. $5 \times \tau$

Output: SPDT relay:
Contact material, AgNi 0,15 with hardened gold plating Au.
Max. load AC: 8A/240V AC ($\cos \varphi=1$)
Max. breaking capacity 2000VA. Inductive load. See fig. 1.
Max. load DC: 8A/24V DC
Max. breaking capacity 50-270W. See fig. 2.

Max. in rush current: 15A(max. 4s/duty cycle less than 10%).

Min. in rush current: 10mA, 24V DC

Frequency: Max. 1000 operations pr. time.

Life span: Mech. Min. 3×10^7 operations
Elect. Min. 1×10^5 operations with full load.

Delay: <20ms.

Analogue outputs: 0-10V DC, refers to setpoint and measured temperature in chosen areas.
 $I_{max} = 2mA / R_{load} > 5 k\Omega$.
Setpoint: ±1%
Measured value ±5%

Supply voltage: Versions: 924=24V DC (20,4-27,6)V DC
115=24/115V AC (20,4-27,6 /98-132)V AC
230=24/230V AC (20,4-27,6/196-264)V AC
45-65Hz.

Net frequency: AC; 3VA
Consumption: AC; 3VA
DC; 2W

General data: Ambient temperature:-20 to 55°C.
Storage temperature:-40 to 80°C.
Mounting: 35mm DIN-rail (EN50022).
Terminals: Screw terminals with dual compartment.
Terminal screws are combined crosshead/slotted.Up to $2 \times 2,5mm^2$ wire ($2 \times 1,5mm^2$ inc. ferrule).
Recommended torque, 0,5 Nm, max. 0,7 Nm (VDE0609-1).
Terminal identification in accordance with DIN46199/EN50005.

Indicators: Green LED = operating voltage.
Red LED (constant)= relay switched on.
Red LED (flashing)= non-functional probe.

Protection: IP20.

Electric isolation: 3,75kVAC (1 min.) between input, supply and relay output (EN60950).
Note: No galvanic isolation between input and analogue output.
Noryl (GE), UL94V1.
Terminal block:Noryl (GE), UL94V0.

Housing: Noryl (GE), UL94V1.
Terminal block:Noryl (GE), UL94V0.

Weight: 180 g.

WIRING DIAGRAM

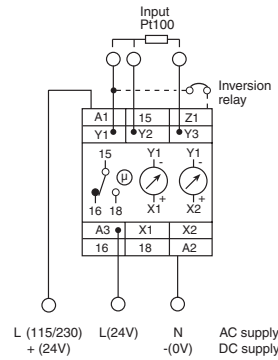

Coding: Relay inverter, Jumper Y1-Z1

Analogue output 0-10V DC
Setpoint: X1= (+) V
Y1= (-) 0

Measured temperature: X2=(+) V
Y1=(-) 0

SPECIFICATIONS:

- MXT-10 is designed and developed with regard to relevant specifications:
- EN60204-1 / VDE0113 electrical material on machines.
 - VDE0110 / IEC664 Isolation specifications/creepage and clearance distances.
 - Electrical safety in accordance with EN61010.
 - IEC414 Safety regulations for control and monitoring equipment.
 - EMC: Emission EN50081-1
Immunity EN50082-2
 - Humidity in accordance with IEC68-2-3; RH=95%, 40°C.
 - Vibration in accordance with IEC68-2-6;
 - Shock when mounted, in accordance with IEC68-2-27.

MXT-10 is CE-marked in accordance with EMC-and the Low Voltage Directive.

OUTPUT LOAD DIAGRAMS

Fig. 1

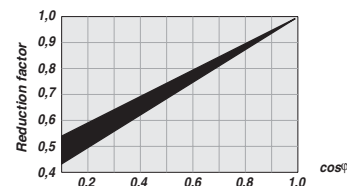

Fig. 2

